

# Case Making

John Pipe have made export packing cases for 40 years. Over the decades designs have been developed, improving cost and efficiency.

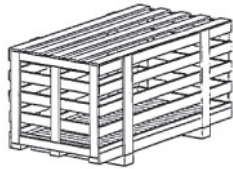

### DIB A CRATE

An economic design to use which offers physical handling protection

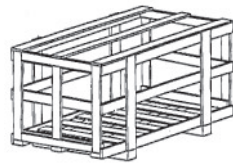

### DIB A OPEN CRATE

A skeletal crate design for less cost

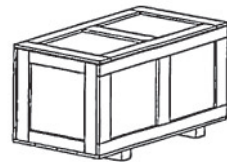

### PLY RIB A CASE

A traditional design of plywood case for suitable for lighter contents

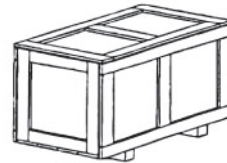

### PLY RIB B CASE

Sides can be nailed on after the contents have been positioned on the base.

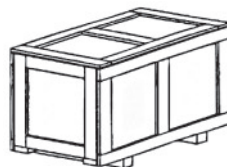

### PLY DIB CASE

Similar to the timber 'DIB' design, this case has the lightness and rigidity of plywood but is additionally reinforced with the 'skid' timber members.

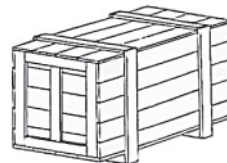

### RIB A CASE

General use packing case for lighter goods lined with water-resistant bitumenised paper, or unlined.

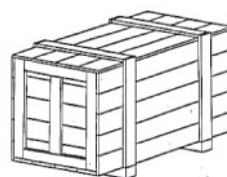

### RIB B CASE

As 'RIB A' except that case construction allows for case sides to be nailed on after equipment has been positioned on base.

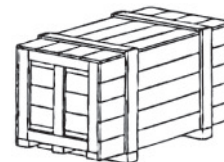
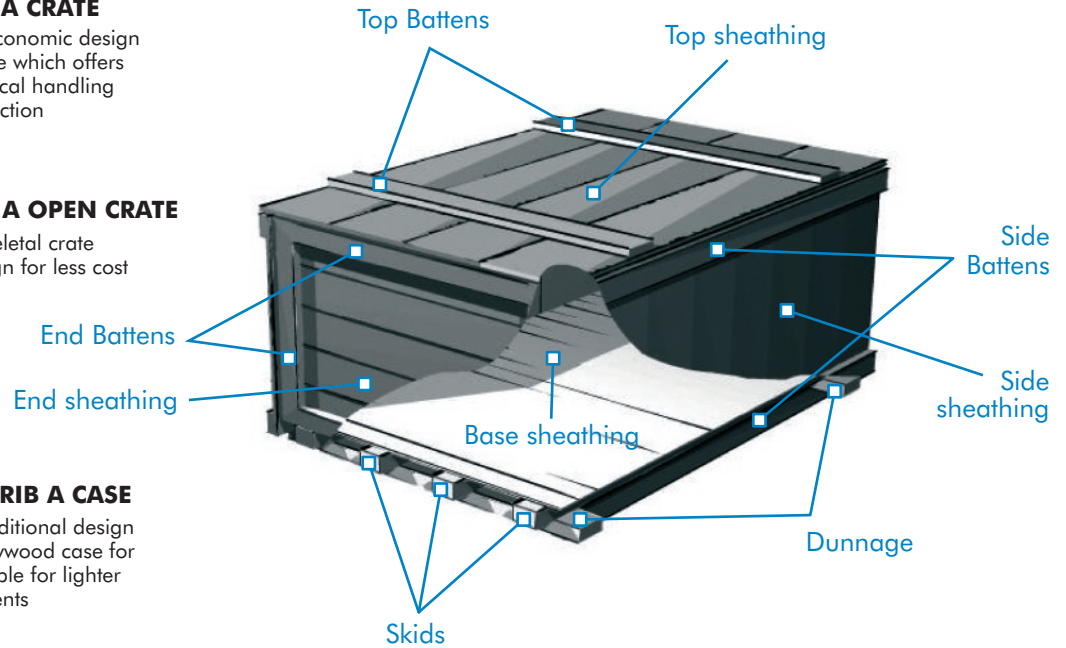

### DIB A CASE

This case has a stronger base for heavier equipment and allows for case sides and ends to be nailed on after equipment has been positioned on the base. This is a very useful feature especially when items are to be sealed in foil for protection against corrosion.

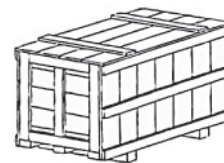

### DIB B CASE

As 'DIB A' but with horizontal internal bracing. This case gives good longitudinal rigidity when lifted using slings or fork-lift truck.

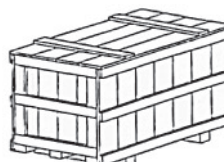

### DIB C CASE

As 'DIB A & B' but with vertical bands to sides and ends giving a greater stacking ability. This type of case is also used when very heavy but low in height; either wide or long.



**JOHNPIPE**  
INTERNATIONAL

EST. 1961

PACKING & FREIGHT

Dorset Tel: (01202) 715888  
Hampshire Tel: (02380) 360100

[www.johnpipe.co.uk](http://www.johnpipe.co.uk)